



## Steel Structures 1

### Tutorial Set 5 – Connections

1) *From 1998 Exam*

Two 150UC30.0 sections, Grade 300 to AS 3679, are connected with splice plates connected to the top and bottom flanges of each section, as shown in Figure 5(a). There are 2 lines and  $n$  rows of bolts on each flange. (Note that if there are  $n$  rows of bolts, then there is a total of  $8n$  bolts in the entire connection.) Grade 4.6 snug tight M20 bolts are used in this connection, and the plane between the splice plate and the flange of the UC section coincides with the *threaded* part of the bolt. Each splice plate is Grade 300 to AS 3678, and is 120 mm wide and 16 mm thick

- (i) **What is the minimum number ( $n$ ) of rows of bolts required to ensure that the connection is adequate for a design axial tension of  $N^* = 795$  kN.** (You are *not* required to calculate the section capacity in tension of either the UC or the splice plates. For the UC section  $\phi N_t = 868$  kN, and for each of the splice plates  $\phi N_t = 400$  kN.). **Also include the design capacity for the connection based on the number of bolts you have chosen.**
- (ii) The bolts are replaced by fillet welds, SP Grade, made from E48XX electrode, and equal leg lengths of 6 mm, as shown in Figure 5(b). **What is the minimum value of the length of the weld,  $L_w$ , required to ensure that the connection is adequate for a design axial tension of  $N^* = 795$  kN?** Note that there will be eight (8) individual fillet welds, each of length  $L_w$  in the entire connection. **Also include the design capacity for the connection based on the length of weld you have chosen.**

The following properties of an M20 bolt may be useful.

Core area,  $A_c = 225$  mm<sup>2</sup>.

Shank area,  $A_o = 314$  mm<sup>2</sup>.

Tensile stress area,  $A_s = 245$  mm<sup>2</sup>

Diameter of the hole,  $d_h = 22$  mm

**It is anticipated that students should be able to complete most of these tutorial questions during the allocated tutorial time.** *In the exam only annotated versions of the Standard AS 4100 and the BHP/OneSteel section properties are permitted. Hence it is good practice to attempt these questions using just the standard AS 4100 and not referencing the lecture notes.*

*Tim Wilkinson*

Lecturer in Civil Engineering

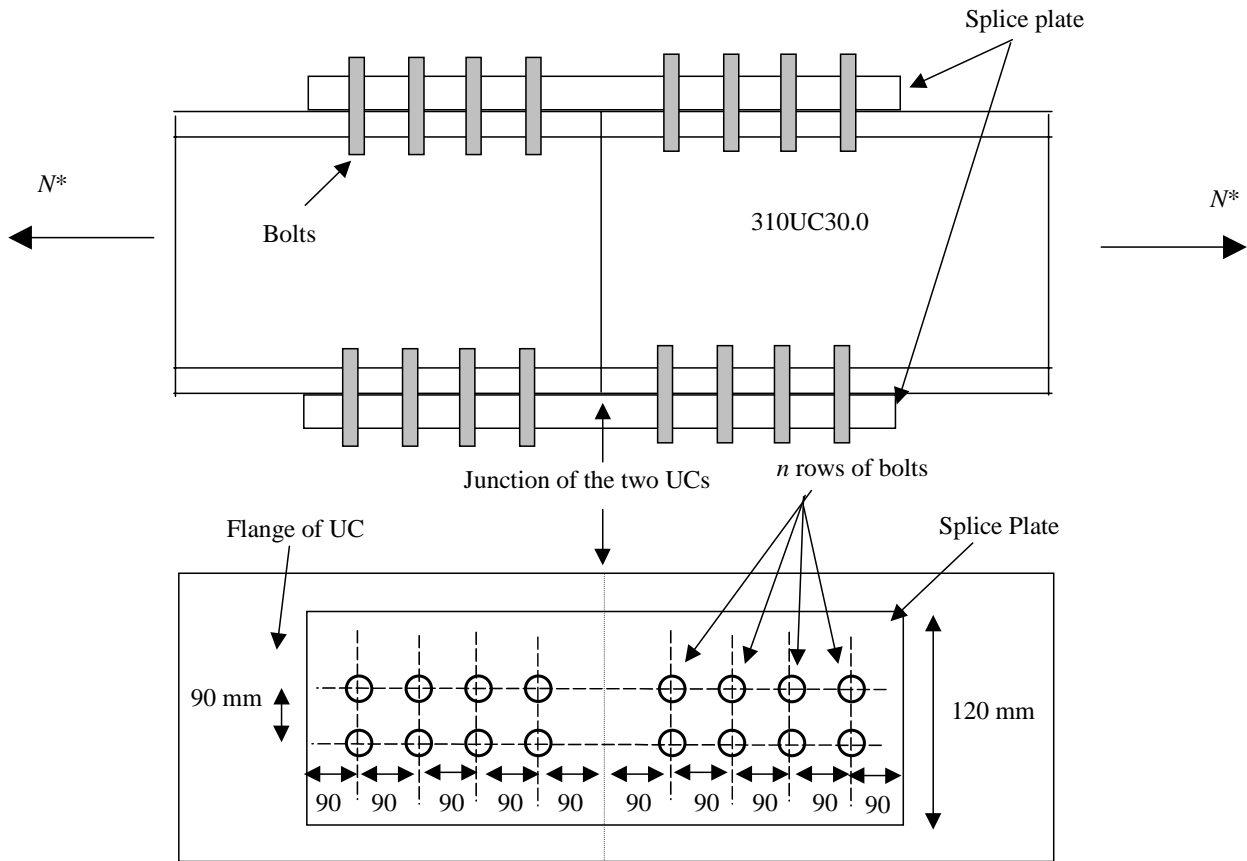

**Note: This figure shows 4 rows of bolts, as a guide only.  
The question is to determine the number,  $n$ , of rows of bolts required.**

(a) Plan

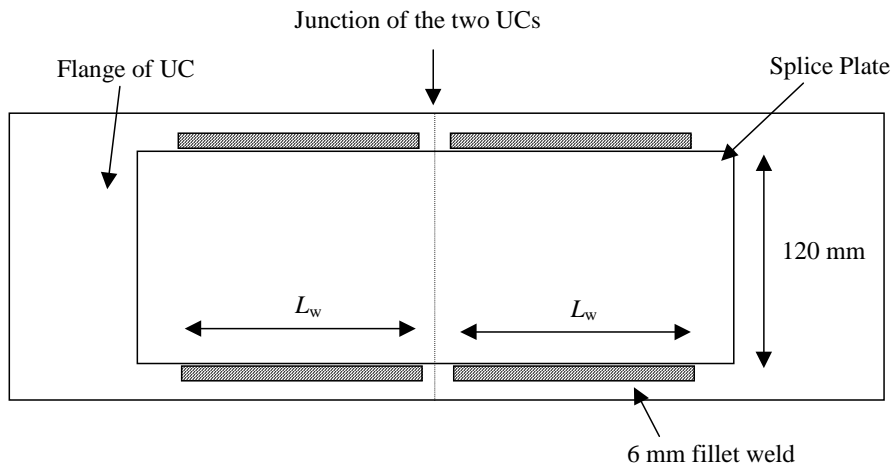

(b) Plan

Figure 5

(All dimensions in mm)