



The University of Sydney

CIVL3227 Steel Structures 1/CIVL3206 Steel Structures 1

Department of Civil Engineering

Semester 2, 2002

Time Allowed: 3 hours

Instructions to Candidates

- (a) **Students should attempt all questions.**
- (b) Suitable working, diagrams and explanations are required for each question.
- (c) Marks may be deducted for work that is not satisfactorily set out.
- (d) Units are important and answers with incorrect units will not be awarded full marks.
- (e) Programmable and non-programmable calculators may be used.
- (f) Read the questions carefully before answering.
- (g) Annotated copies of AS 4100 (or the student edition HB2.2) may be taken into the exam, but no other written material is permitted. Additional pages are not to be inserted into AS 4100 (or HB 2.2).
- (h) Students are reminded that satisfactory exam performance is an essential criterion in this unit of study, and a total mark of 40%, and minimum 50 % mark in at least 2 exam questions, is required.
- (i) The exam is worth 55 % of the final assessment in the “structures” component of this unit of study.
- (j) This paper contains 5 questions: Tension (15 %), Bending (25 %), Compression (25 %), Combined Actions (20 %), Connections (15 %).

Q 1 Tension Members (15 marks)

- a) Table 7.3.2 of AS 4100 gives different values of the tension correction factor k_t for single unequal angles connected by the long leg or by the short leg.

Briefly explain why the correction factor is different for the two cases. There is no need to perform any calculations in answering this question. Diagrams may be useful in answering this question.

- b) Single $150 \times 90 \times 10$ Unequal Angles in Grade 300 steel are being used as diagonal tension members in a truss. A typical UA member is connected to each chord of the truss using M20 bolts through the long leg of the UA only, and the pattern of 22 mm diameter bolt holes is shown in Figure 1 below. The capacities of the bolts in shear, and the ply in bearing do not need to be considered.
- i) **Sketch the relevant fracture patterns** that may occur in the UA section in order to determine the net area (A_n).
- ii) **What is the design section capacity in tension (ϕN_t) of the angle section?**
- iii) If an additional (vertical) column of 2 bolts was added 60 mm to the left of the current bolts, **how would the answer to part ii) change? Explain your answer** – however calculations are not necessary.

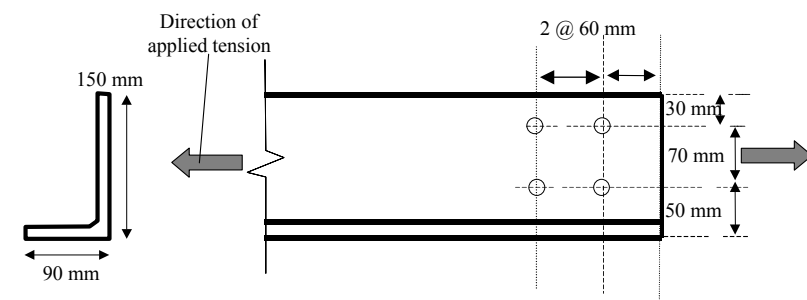

Figure 1: Bolt hole pattern in $150 \times 100 \times 10$ UA Grade 300

Q 2 Bending (25 Marks)

- a) **Explain the different types of behaviour of beam sections – compact, non-compact and slender.** Use of a moment vs curvature graph showing the different behaviour would assist the answer.
- b) A rectangular portal frame, constructed from 250UB37.3 members in Grade 300 steel, has a height of 4 metres and a span of $L = 8$ metres as shown in Figure 2 below. The webs of the members are oriented so that they lie within the plane of the frame. Figure 2 also shows the BMD of the frame for a uniformly distributed load w acting downwards on the rafter.

The rafter has full restraint (F) at the column-rafter connection, but this connection does not provide any rotational restraint. After installation, purlins at regular spacing will connect the roof sheeting to the rafter and at each purlin location there is fly bracing to the bottom flange of the rafter. This arrangement can be considered to provide a full restraint (F) to both flanges of the rafter at the points of attachment.

The engineer has been asked to evaluate the strength of the frame before and after installation of the purlins.

- i) **Does the structural analysis program used to produce the BMD in Figure 2 draw the bending moments on the tension or compression side of members in bending?**
- ii) **Determine the design section capacity for x -axis bending (ϕM_{sx}) of the 250UB37.3.**
- iii) The engineer wishes to place the purlins at close enough intervals to ensure that lateral buckling of the rafter does not occur. **Use Clause 5.3.2.4 of AS 4100 to determine the maximum purlin spacing** required to ensure that the member moment capacity of the rafter may be taken as equal to the section moment capacity. **What is the maximum value of the downwards UDL w in this case? Would there be any difference to the answer if the UDL was upwards (eg due to wind uplift)? Briefly explain your answer.**
- iv) **Explain briefly what different design aspects should be considered if evaluating the strength of the beam during the construction phase before the purlins and sheeting are installed.**

Clearly identify the values of all appropriate variables calculated and include the relevant units.

If required, the values of Z_{ex} , Z_{ey} and k_f may be taken from the OneSteel product literature.

The diagram is on the next page.

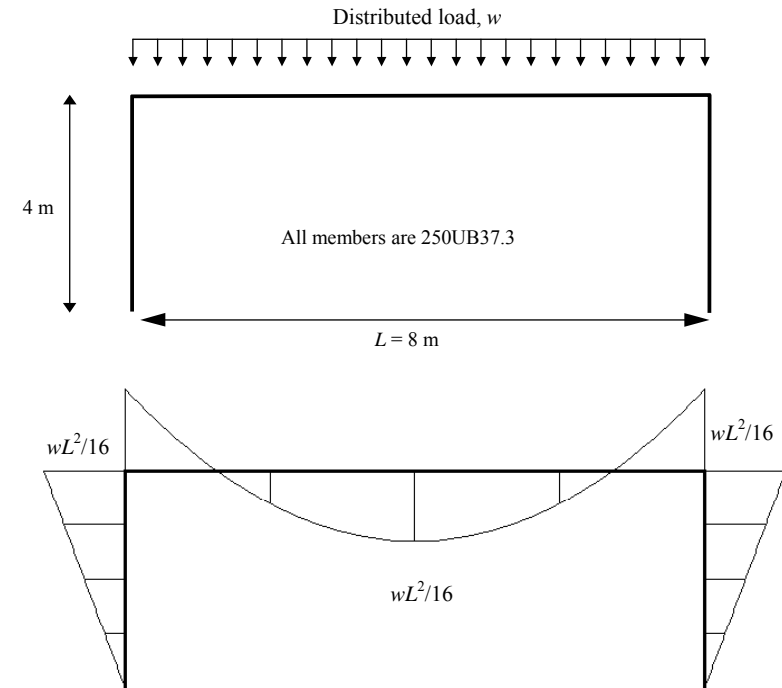

Figure 2: Portal Frame Under UDL w on the Rafter

Q3 Compression Members (25 Marks)

- a) Frame A (shown in the figure below) consists of beams and columns rigidly connected, with rigid footings. All beams are 3 m long and each storey height is 3 m. The design engineer has calculated the in plane effective lengths of the columns in accordance with AS 4100. The engineer is then asked to consider a redesign of the frame (shown as Frame B), in which the same sections and connections are used, but the beam lengths are increased to 4 m while the storey height remains 3 m.

How (if at all) are the column in plane effective lengths in the redesign of Frame B affected with respect to the original in plane effective lengths in Frame A? Explain your answer. No numerical calculations need to be performed in answering this question.

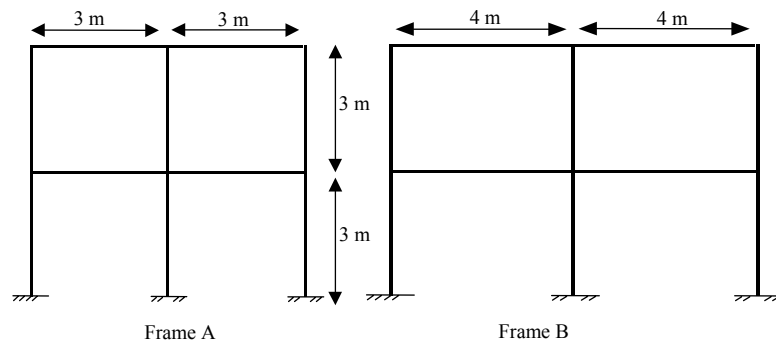

Figure 3a) Possible framing alternatives

- b) Consider the frame shown. All columns are 200UC59.5 and all beams are 250UB37.3 in Grade 300 steel. The columns are 5 m apart in both the north-south and east-west directions and each storey is 4 m in height. All beam column connections in both the north-south and east-west directions are rigid. The column base plate connections should be considered as fixed in both directions. The webs of all columns are oriented east-west and all beams are oriented such that the flanges are horizontal. Column 1 is in the lower storey in the north-east corner of the building.

- Draw a plan, and a north-south and an east-west elevation. With reference to these diagrams, establish how buckling about the x and y axes of Column 1 relates to buckling in the north-south, and east-west planes.
- For Column 1, determine the effective length for buckling in the north-south plane. (*Hint: think carefully about x and y axes*)
- Determine the design member capacity (ϕN_c) of Column 1 for buckling in the north-south plane. Is the column adequate for design axial compressions of $N^*_{Col 1} = 1000$ kN?

If required, the any relevant values should be taken from the OneSteel product tables.

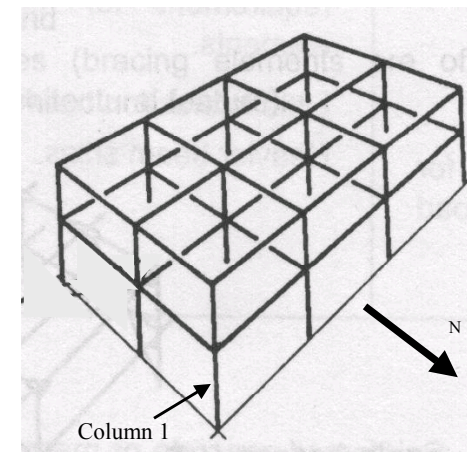

Figure 3b: Representation of 3D Frame

Q4 Combined actions (20 Marks)

- a) Briefly explain the difference between a *first-order* and a *second-order* bending moment.

It may be appropriate to write some relevant equations and draw some diagrams in your response, but there is no need to perform any numerical calculations. Directly quoting from AS 4100 is not considered an appropriate answer.

- b) A rectangular portal frame ABCD subjected to a design load combination is shown in Figure 4(a). All members are bent about their major (x) axis in the plane of the frame. The connection between the beam and the column at B is a flexible (pinned) connection, while that at C is a rigid connection. The support at A is fixed against translation and rotation and the support at D is pinned. The bending moment and axial force diagrams obtained by conducting a *first order elastic analysis* of the frame are shown in Figures 4(b) and 4(c), respectively.

Each member of the frame is braced by a lateral and torsional restraint at its ends and midpoint so that the beam effective length (L_e) and out of plane column effective lengths (L_{ey}) of each segment is equal to half the actual member length ($L_e = L_{ey} = 0.5L$). The lateral and torsional restraints are indicated in Figure 4(a).

The design engineer has analysed the frame and determined the effective length factors for in-plane buckling of the columns as $k_{ex,AB} = 2.2$, and $k_{ex,CD} = 2.1$, as well as a sway moment amplification factor of $\delta_s = 1.20$.

- i) Since column CD has full restraint at both ends and the midheight, an engineer should consider two segments – the upper and lower segment. Without performing any calculations, **which segment is the more heavily loaded as a beam-column, and why?**
- ii) **What is the design second order moment for CD?**
- iii) **Determine the out of plane member strength (ϕM_{ox}) of member CD** and hence establish if Cl 8.4.4.1 of AS 4100 is satisfied.

If required, the values of Z_{ex} and k_f may be taken from the OneSteel product literature.

The diagram is on the next page.

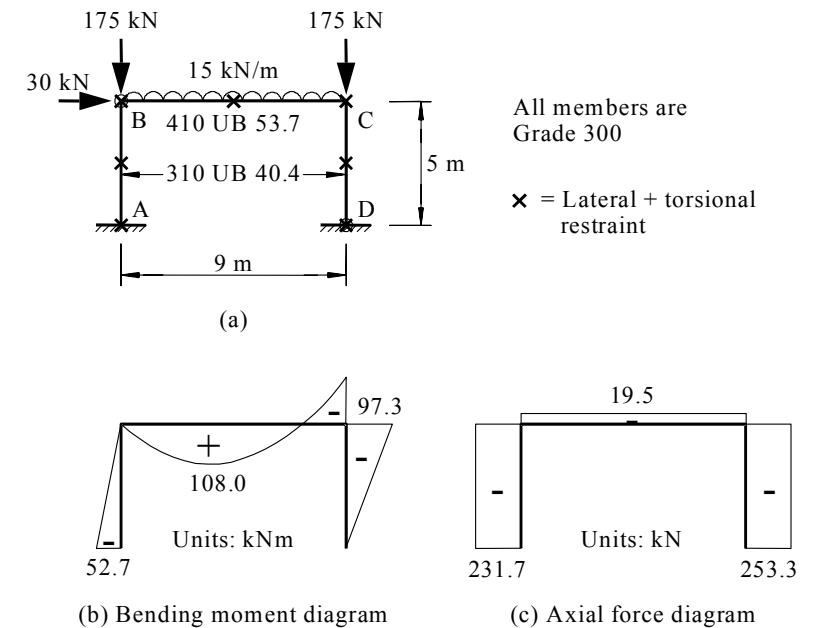

Figure 4

Q5 Connections (15 Marks)

- (a) **Give two methods** of guaranteeing the specified pre-tension in a fully-tensioned high-strength bolt. Directly quoting from AS 4100 is not considered an appropriate answer. Use of diagrams would greatly assist the answer.
- (b) A Grade 8.8 M20 bolt experiences both tension and shear (through the threaded cross-section). The bolt experiences a design shear force of $V_t^* = 20$ kN. **What is the maximum design tensile force (N_{tr}^*) the bolt can hold?** (Hint: Cl 9.3.2.3)
- (c) An engineer is assessing the tensile strength of a bracing connection in which a $200 \times 200 \times 20$ EA (Grade 300) is bolted to a 25 mm thick gusset plate (Grade 300 to AS/NZS 3678) by 6 bolts as shown in Figure 5. The bolt pitch is 75 mm. Grade 8.8 snug tight M20 bolts are used in this connection, and the plane between the gusset plate and angle coincides with the *threaded* part of the bolt.
- (i) **List the various failure modes that should be considered when calculating the design capacity of this connection.**
- (ii) **What is the design capacity of the connection?** (Students are *not* required to calculate the section capacity in tension of the angle. For the angle section $\phi N_t = 1930$ kN). **What is the critical failure mode of the connection?**

The following properties of an M20 bolt may be useful.

Core area, $A_c = 225$ mm².

Shank area, $A_o = 314$ mm².

Tensile stress area, $A_s = 245$ mm²

Diameter of the hole, $d_h = 22$ mm

The diagram is on the next page.

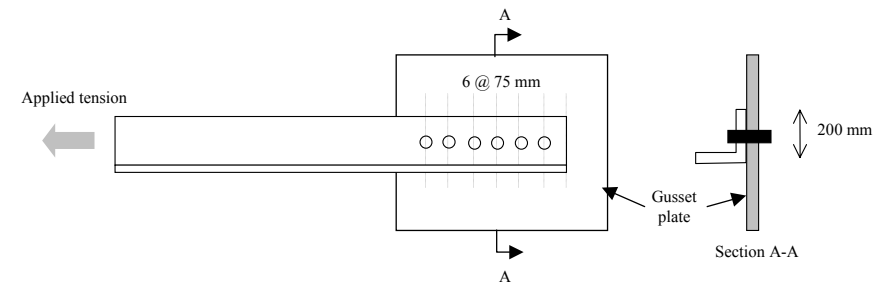

(a) Plan

Figure 5

(All dimensions in mm)

This is the end of the questions in this examination paper.

The next 5 pages should contain OneSteel product information on UBs, UCs, EAs & UAs.